

INSTALLATION

DBM3D Digital Battery Monitor



Features

- 7 Segment green led Display
- Dimmer facility
- Battery voltage accurate to 0.10 Volt
- Alternator voltage accurate to 0.30 Volt
- Main and Auxiliary Battery Monitoring
- Mounting Kit and Bracket included
- Slim Design
- Under / On / Over Dash Mountable
- Three Position Switch
- Wiring Loom with Flat cable section
- Extremely low current draw



HIGH VOLTAGE DISPLAY



LOW VOLTAGE DISPLAY

Installation

- Simple four wire connection

	Black Wire	- Earth
	Orange Wire	- Dash Light
	Red Wire	- Main Battery
	White Wire	- Auxiliary Battery

For best results in reading this monitor, we recommend mounting the monitor in a horizontal position, so that the switch is in a vertical position.

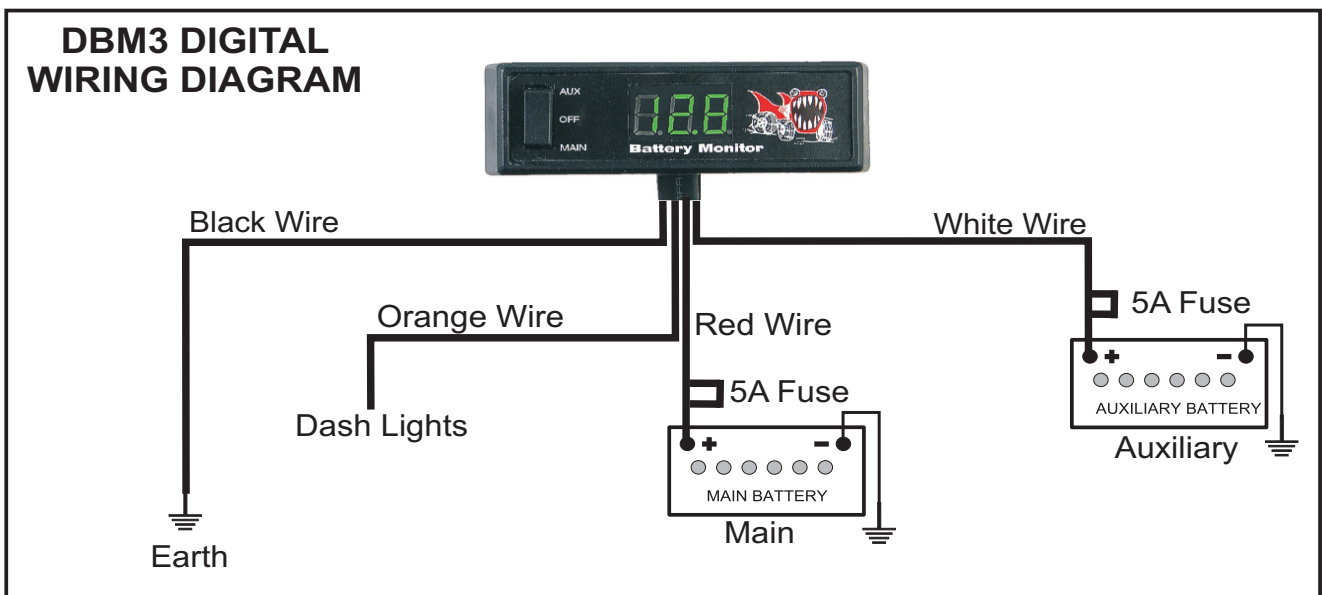

piranha
OFF ROAD PRODUCTS

Piranha Off Road Products
Factory 4, 383 Dorset Road
Boronia VIC 3155
Ph: (03) 9762 1200
Fx: (03) 9762 1400
www.piranhaoffroad.com.au

Piranha use & recommend:



AUSTRALIAN DESIGNED, MADE & OWNED